

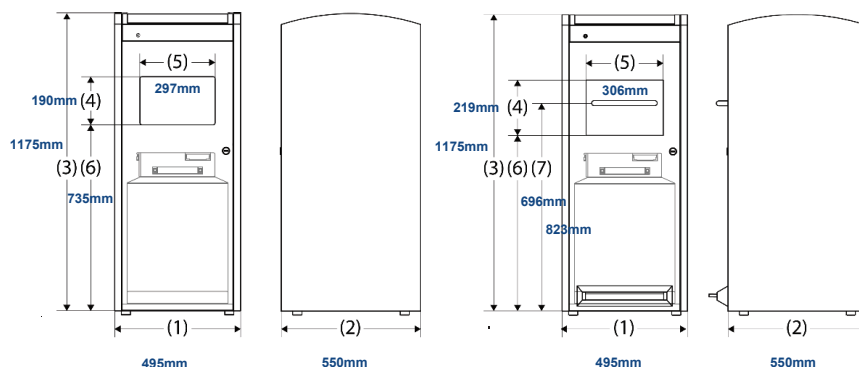

# Exe Holding - COS GUNOI FOTOVOLTAIC 100L CU SISTEM COMPACTOR

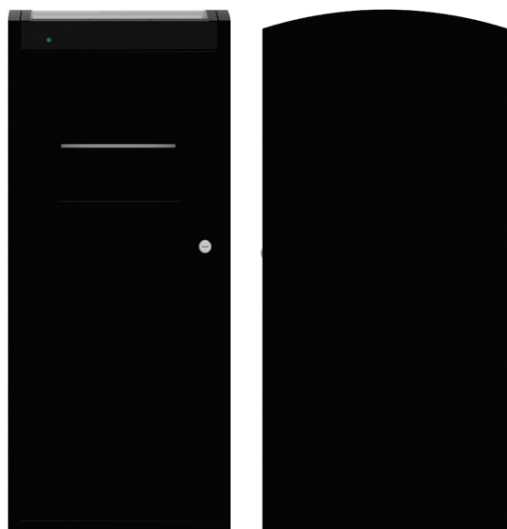

## DATE ELECTRICE

Voltage [V]	12V DC
Baterie	Deep-cycle battery (12V 18Ah)
Panou solar	polycrystalline (20W)
Putere consumata	15Wh / zi
Status	1 indicator LED (3 culori) care indica nivelul de umplere si starea operationala

## DIMENSIUNI

Lungime[mm]	495
Latime [mm]	550
Inaltime [mm]	1175

## DATE SISTEM COMPACTOR

Forta	max 300kgf
Durata	60s / ciclu
Specificatii motor	1/12-HP DC motor (60W)
Mecanism	motor-operated X-frame (patented)
Masurare nivel umplere	senzor

## DATE TEHNICE

Materiale	Structura din otel electrogalvanizat si otel inoxidabil, capac de protectie din policarbonat pentru panoul solar
Finisaj	Negru (vopsea pulbere)
Echipment comunicare	4G LTE module, GPS module
Siguranta	Dispozitiv de blocare a usilor din fata cu cheia Senzor de detectare a mainii la deschidere Senzor de fum pentru detectare incendii

